



**USER MANUAL**  
**Digital Wireless Belt Station**  
**U9110-BSW**  
**(P/N: 40992G-19)**



## Cautions and Warnings

**READ AND SAVE THESE INSTRUCTIONS.** Follow the instructions in this installation manual. These instructions must be followed to avoid damage to this product and associated equipment. Product operation and reliability depends on proper usage.



**DO NOT INSTALL ANY DAVID CLARK COMPANY PRODUCT THAT APPEARS DAMAGED.** Upon unpacking your David Clark product, inspect the contents for shipping damage. If damage is apparent, immediately file a claim with the carrier and notify your David Clark product supplier.



**ELECTRICAL HAZARD** - Disconnect electrical power when making any internal adjustments or repairs. All repairs should be performed by a representative or authorized agent of the David Clark Company.



**STATIC HAZARD** - Static electricity can damage components. Therefore, be sure to ground yourself before opening or installing components.



**LI-POLYMER** - This product is used with Li-Polymer batteries. Do not incinerate, disassemble, short circuit, or expose the battery to high temperatures. Battery must be disposed of properly in accordance with local regulations.

## Overview

The U9110-BSW (40992G-19) Digital Wireless Belt Station is a portable wireless communication device that when used in conjunction with a U9120-W4 (44002G-01) Digital Wireless Gateway becomes part of a wireless intercom system. Up to four belt stations can be connected to one gateway.

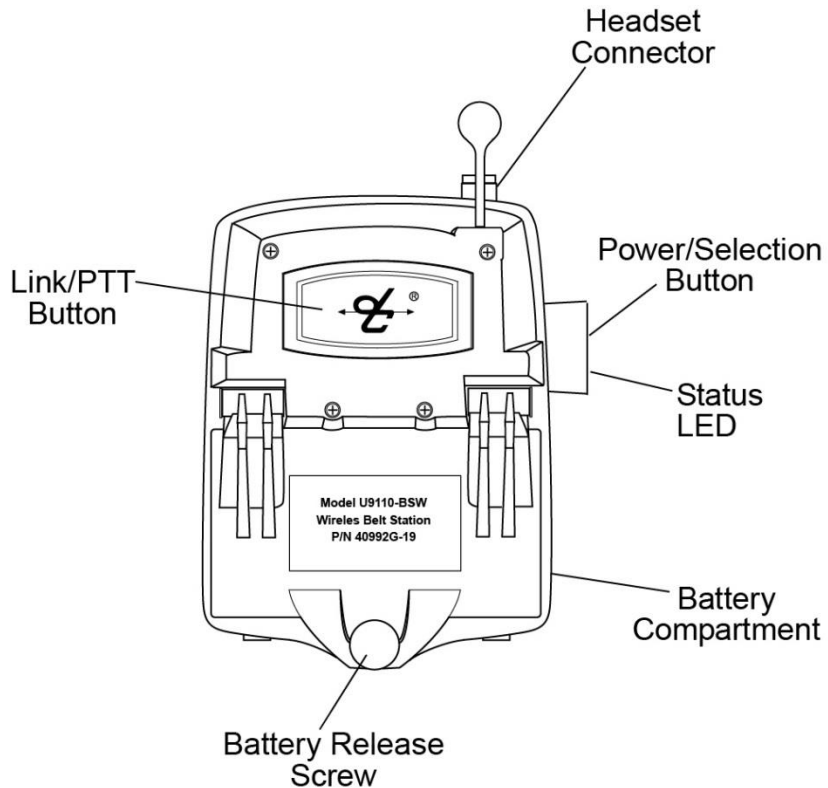

**Figure 1: Overview of Belt Station**

The U9110-BSW Digital Wireless Belt Station employs an adaptive SMART-VOX system which does not require adjustment by the user. The system automatically monitors background noise levels and detects voice.

## Linking

Before a belt station and a gateway can be connected, they must first be **Linked**. As a security measure, the **close-link** feature requires devices to be in proximity of about 1 to 3 ft (0.3 to 0.9m) in order to successfully link. This ensures that the units are not inadvertently linked with other units on the premises.

Linking procedure:

1. Ensure units are within 1 to 3 ft (0.3 to 0.9m) of each other.
2. Ensure the U9110-BSW is not already connected (see **Status Indication**).
3. Simultaneously (within 1-2 sec) press and release the PTT button on the U9110-BSW and the gateway to link with.
4. Amber LED's will flash on both devices. A momentary red LED indicates a successful close-link.
5. Upon successful link the U9110-BSW will attempt to establish a connection with the gateway.
6. Upon successfully establishing connection the LED will flash green, a voice alert will be heard (see **Table 1**), and user side-tone will be enabled (see **Communication**).
7. Link and connection are now complete.

Each belt station is able to be linked to only one gateway at a time. A gateway can have up to four belt stations linked/connected at one time.

### **Tip:**

Once linked, the devices will not need to be linked again unless they are purged (see **Purging**).

## Status Indications

The power button has a multi-color LED in the center which serves as a status indication for the belt station. **Table 1** below lists these states.

**Table 1: LED Status Indication**

LED Color	Blink Rate	Status
Red	Solid	Initializing/power up
Red	Solid	Close-link successful
Red	Any	Low battery (approx. 1 hr remaining)
Orange	Slow	Idle/Disconnected
Orange	Fast	Link/Connection in progress
Orange	Solid	PTT asserted
Green	Slow	Connected

In addition to the LED, the belt station provides audio feedback for certain conditions as well. **Table 2** below lists these conditions.

**Table 2: Alerts**

"Connection Established"
"Connection Lost"
"Low Battery"
"Connection Deleted" (see <i>Purging</i> )
Triple Beep – Fringe Signal Area
"1,2,3 or 4" – Selection Indication (see <i>Operation</i> )

## Operation

### *Power-up/power-down*

To power up the U9110-BSW belt station, press and hold the POWER button for approximately two seconds. The LED will turn red and then begin flashing orange. If the belt station has been linked to a gateway and that gateway is in range, the belt station will automatically connect within a few seconds.

To power down the U9110-BSW, press and hold the POWER button for approximately two seconds. The LED will turn red and then turn off. The belt station is now powered down.

### *Auto Shut-off*

Additionally, the belt station will automatically power down if it is disconnected from its gateway for more than 30 minutes.

### *Headset*

In order for the U9110-BSW to be used, a David Clark H9100-series headset must be connected. To connect the headset, align red keyways and push. Pull back gently on the connector (behind the quick-release collar) to ensure it is properly locked. To disconnect, pull back on the quick-release collar.

There are separate left and right volume controls on the headset.

It is also important to properly wear the headset and correctly position the microphone. For optimum noise-cancelling performance, position the microphone 1/8" to 1/4" (3-6 mm) from your lips.



**Figure 2: Positioning the Microphone**

### *Communication*

The user will hear his own voice (side-tone) only when the belt station is linked to a gateway, assuming the microphone programming for intercom on the chosen selection is either hot-mic or VOX; if the selection for mic function for intercom was programmed for PTT, the user will hear side-tone when the PTT is depressed. Side-tone provides feedback for the user to know he is connected. In general, if you can hear your own voice, the other users can hear you as well.

### *Range*

The unimpeded line-of-sight range of a belt station and a gateway should be at least 300 ft (100m). If you are in an environment with metal or concrete walls, this range could be reduced. If the belt station enters into a "fringe" reception area, a brief sequence of three beeps will be heard in the headset. This is to serve as a warning of a possible disconnection if conditions are not improved. When possible, the user should attempt to regain line-of-sight contact with the gateway. When the belt station travels out of range of the gateway, a voice prompt will indicate that the connection has been lost. To reconnect, simply move back into range and connection with the gateway will automatically be reestablished, also noted by a voice prompt.

### *PTT*

The PTT button allows the user to activate the headset's microphone momentarily while depressed. The actual microphone transmit function (e.g., radio transmit or intercom) will depend on the specific programming for the chosen selection on the belt station. For more information see the Operation Digital Intercom manual (19549P-31). (see section on User Interface to review programming options).

### *Selections*

The U9110-BSW has the capability of switching between four "selections". These selections are defined within the Digital Intercom System graphical user interface and can be configured to provide different communications paths between users and radios, as well as the behavior of auxiliary audio devices connected to the system.

*To cycle through the four selections, briefly press and release the power button. A voice prompt will indicate the selection. For more information on selections, please see the Digital Intercom manual (19549P-31).*

#### *Low Battery*

Under normal conditions, a belt station's battery can be expected to last for approximately 24 hours of continual use (*Note: if a Hear-through headset model is in use, this nominal use time could be reduced by as much as 50%, depending on noise conditions and amplification level*). A voice prompt will indicate to the user that the battery is running low. Additionally, the Status LED will turn red, at which point approximately 1 hour of operation would remain.

## **Purging**

In some circumstances it may be desired to “purge” the U9110-BSW of its known gateway. Typically purging is not necessary unless there are multiple gateways in the same vicinity and you wish to link a belt station to a different gateway. A belt station can be linked to only one gateway at a time.

#### *Purge Procedure*

1. Power down belt station (see **Power-up/Power-down**).
2. Press and hold PTT button. Do not release.
3. Power up the belt station (see **Power-up/Power-down**).
4. Release POWER button when red LED turns off.
5. Release PTT button.
6. A voice prompt will indicate that the connection has been deleted.

When this procedure is complete, the belt station will not automatically connect to a gateway and must be linked again.

## **Battery Removal & Charging**

The U9110-BSW uses a 3.7V Li-Polymer rechargeable battery. This battery is removed by loosening the battery release screw (See **Figure 1**). These batteries are charged with the A99-14CRG 4-bay battery charger (41034G-02).

When installing a battery, take care to align the battery properly and fully tighten the screw (see **Figure 3**).



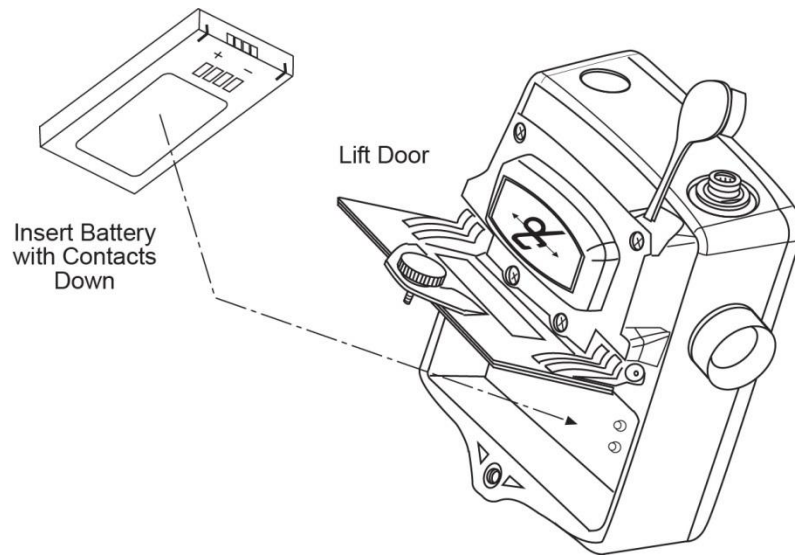

**Figure 3: Battery Insertion/Removal**

## Troubleshooting

**Table 3: Troubleshooting**

Problem	Solution
Belt Station will not turn on	Review <i>Power-up/Power-down</i> procedure Ensure a fresh battery is installed
Cannot link a belt station	Review <i>Registration</i> procedure Ensure units are within 1 to 3 ft. (0.3 to 0.9m) of each other while linking
No sidetone	Not connected to a Gateway
Low receive audio	Adjust left/right volume knobs on headset
No audio /intermittent audio	Check headset connection to belt station

## Replacement Parts

- Battery (P/N: 40688G-90)
- Protective skin, black (A99-01SKN, P/N: 40796G-02)

## Care and Maintenance

The U9110-BSW is not user serviceable. Do not attempt to open the enclosure. If this product requires service, please contact the David Clark Co. Inc. Customer Service department:

- **Phone:** 800.298.6235
- **E-Mail:** [serviceWWW@DavidClark.com](mailto:serviceWWW@DavidClark.com)
- **By Mail:** Customer Service  
David Clark Company  
360 Franklin Street  
Worcester, MA 01604

When necessary, the U9110-BSW may be wiped down with a mild soap and water mixture. Although it is designed as a water-tight device, do not unnecessarily submerge this product in water.

Avoid storage of this product in direct sunlight or high temperature environments.

## Specifications

Frequency Range	1920 MHz - 1930 MHz (U.S. and Canada)
Average RF Power Output	4 mW (100mW peak) (U.S. and Canada)
Range	300 ft (100m) line-of-sight (nominal)
Battery Life	24 hrs continuous use (nominal)
Operating Temperature	-14°F to 113°F (-10°C to +45°C)
Storage Temperature	-4°F to 140°F (-20°C to +60°C)
Power Requirements	3.7V @ 100mA nominal
Battery Type	3.7V 2000mAh Li-Polymer

## FCC Part 15 Statement

### RADIO AND TELEVISION INTERFERENCE

This equipment has been tested and found to comply with the limits for a Class B digital device, pursuant to Part 15 of the FCC rules. These limits are designed to provide reasonable protection against harmful interference in a residential installation. This equipment generates, uses and can

radiate radio frequency energy and, if not installed and used in accordance with the instructions, may cause harmful interference to radio communications. However, there is no guarantee that interference will not occur in a particular installation. If this equipment does cause harmful interference to radio or television reception, which can be determined by turning the equipment off and on, the user is encouraged to try to correct the interference by one or more of the following measures:

- Reorient or relocate the receiving antenna.
- Increase the separation between the equipment and the receiver.
- Connect the equipment into an outlet on a circuit different from that to which the receiver is connected.
- Consult the dealer or an experienced radio/TV technician for help.

You may also find helpful the following booklet, prepared by the FCC: "How to Identify and Resolve Radio-TV Interference Problems." This booklet is available from the U.S. Government Printing Office, Washington D.C. 20402.

\* In order to maintain compliance with FCC regulations shielded cables must be used with this equipment. Operation with non-approved equipment or unshielded cables is likely to result in interference to radio & television reception.

## **Industry Canada Statement**

This device complies with Industry Canada license-exempt RSS standard(s). Operation is subject to the following two conditions: (1) this device may not cause interference, and (2) this device must accept any interference, including interference that may cause undesired operation of the device.

Le présent appareil est conforme aux CNR d'Industrie Canada applicables aux appareils radio exempts de licence. L'exploitation est autorisée aux deux conditions suivantes : (1) l'appareil ne doit pas produire de brouillage, et (2) l'utilisateur de l'appareil doit accepter tout brouillage radioélectrique subi, même si le brouillage est susceptible d'en compromettre le fonctionnement.

## **Unauthorized Changes**

Changes or modifications not expressly approved by David Clark Company, Inc. could void the users' authority to operate the equipment.

## **Usage Restrictions**

Due to the UPCS frequencies used, this product is licensed for operation only in the United States of America and Canada, and those countries that have approved the DECT 6.0 Standard.

## **SAR Statement**

### **Radio wave exposure and Specific Absorption Rate (SAR) information**

This product has been designed to comply with applicable safety requirements for exposure to radio waves. These requirements are based on scientific guidelines that include safety margins designed to assure the safety of all persons, regardless of age and health. The radio wave exposure guidelines employ a unit of measurement known as the Specific Absorption Rate, or SAR. Tests for SAR are conducted using standardized methods with the product transmitting at its highest certified power level in all used frequency bands. The product is designed to meet the relevant guidelines for exposure to radio waves.

This device has been evaluated for and shown compliant with the FCC and IC RF Exposure limits. The unit of measurement for RF exposure is Specific Absorption Rate (SAR). The highest SAR value for this product when tested for use on the body is 0.01W/kg (averaged over 10g).

SAR data information for residents in countries that have adopted the SAR limit recommended by the International Commission of Non-Ionizing Radiation Protection (ICNIRP), which is 0.08 W/kg averaged over the whole body or 2.00 W/kg averaged over ten (10) gram of tissue (for example European Union, Japan, Brazil and New Zealand):

The highest SAR value for this product when tested for use on the body is 0.01W/kg (averaged over 10g).

## **Specifications**

Refer to the U9110-BSW Data Sheet (19549P-51) for specifications.

This product is protected by one or more of the following US patents:

**10,237,415 10,389,884 10,397,408 10,560,825 10,701,211 10,701,212**